

350.1



GB

Valmet 350.1

An unusually flexible, efficient, durable, and versatile harvesting head

Exceptional flexibility and speed meet strength and durability. That's the rare and advantageous combination you get with the Valmet 350.1 – simply one of the market's most well designed, profitable, and versatile harvesting heads.

The secret lies in the extremely well considered design, such as the compact frame and sturdy chassis uniting robustness and efficiency. Or the low weight, which enables you to use a long reach.

Central to the head's high productivity – and to

maximizing timber quality – is the position of the cutting motor. Together with the effective hydraulic system, this ensures fast cutting and helps prevent splitting when crosscutting. Other significant benefits are high reliability and ease of service, with everything from innovative cable routing to easily-accessible inspection points. Choose the Valmet 350.1 for maximum returns – day after day, year after year, whether thinning or clearing.

Technical data

Valmet 350.1 highlights

- Short, compact, and sturdy frame
- Four feed motors with differential lock
- Feed rollers with strong traction force
- Double felling cylinders
- Well protected hosing, hydraulics, and onboard computer
- Dual diameter sensors with cross-calipering
- Easily-accessed and service-friendly hydraulic valve
- Easy length measurement servicing

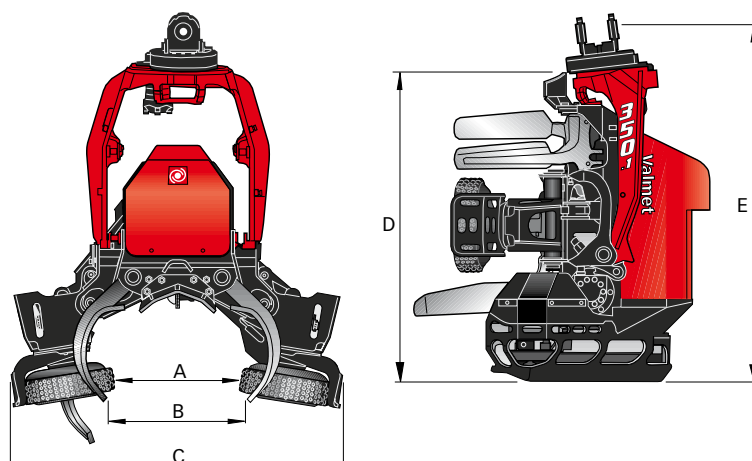

Weight from:	950 kg (2,095 lb)
Feed speed:	0-5 m/s (0-16.4 ft/s)
Feed force gross (roller motor dependent):	16.5-25.3 kN (3,710-5,690 lbf)
Feed wheel type:	Steel rollers
Delimiting knives, number:	4
Delimiting diameter, tip-to-tip:	400 mm (15.75 in)
Bar:	67 or 75 cm (28.4 or 29.5 in)
Cutting motor:	19 cm ³ /rev (1.16 cu in/rev)
Fell/cut diam., theor. max.:	600 mm (23.6 in)
Req. max. hydraulic flow (roller motor dependent):	200-300 l/min (50-80 gal/min)
Requisite max. hydraulic pressure:	250 Bar (3,626 psi)

A Roller opening, max.	520 mm (20.5 in)
B Opening upper knives, max.	600 mm (23.6 in)
C Width, max.	1,400 mm (55.1 in)
D Height to upper knife,	1,300 mm (51.2 in)
G Height including rotator,	1,440 mm (56.7 in)

Optional equipment

Standard and extra equipment are adapted to the market and vary from country to country. Your sales representative will have an up-to-date list of what is included. Technical data/dimensions vary depending on optional equipment selected. Specifications and designs are subject to change without notice. Photos, diagrams, and sketches do not always show the standard model machine.

